

**VSF 11011**

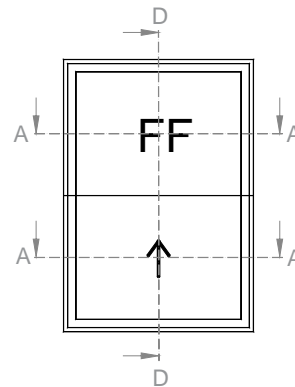

**VSF 21021**  
*als Kämpfer  
waagrecht*

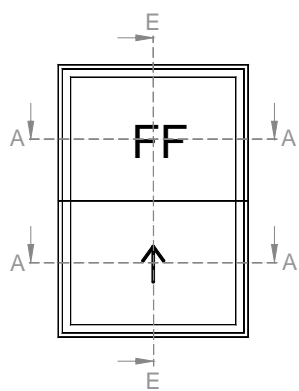

**VSF 21031**  
*als Stulp  
waagrecht*

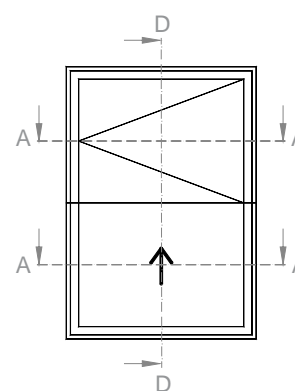

**VSF 21041**  
in 3 Varianten:  
1. als Dreh  
2. als Kipp  
3. als Kipp-Putzschere

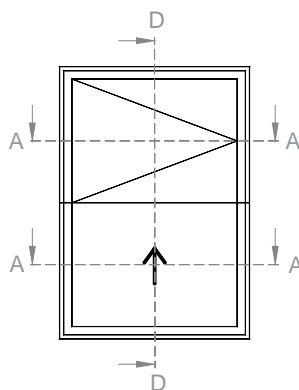

**VSF 21051**

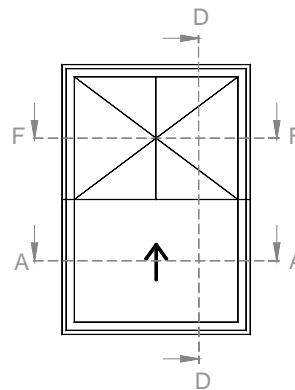

**VSF 31061**  
als Stulp

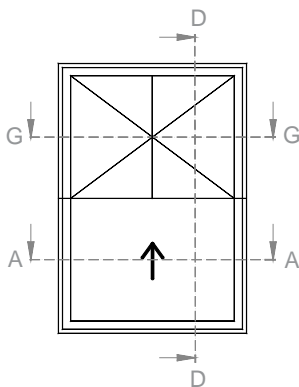

**VSF 31071**  
mit Pfosten

## WIN - Hochschieb Fenster Ausführung VSF 11011

### Schnitt A - A

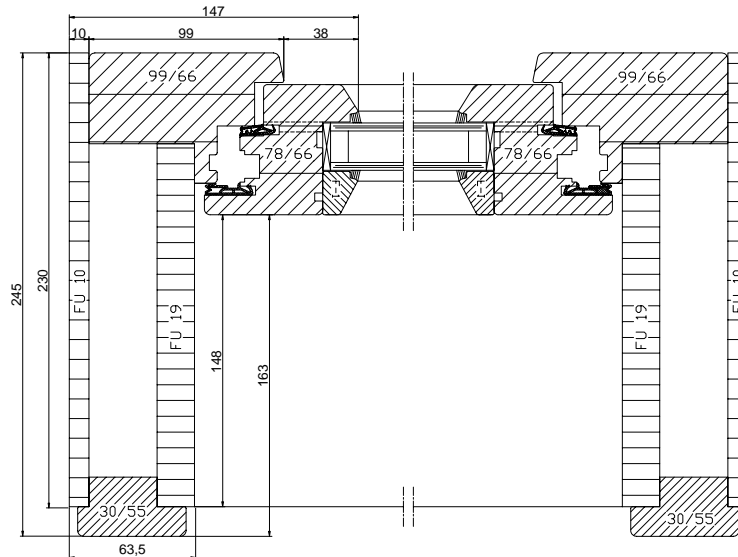

### Schnitt B - B

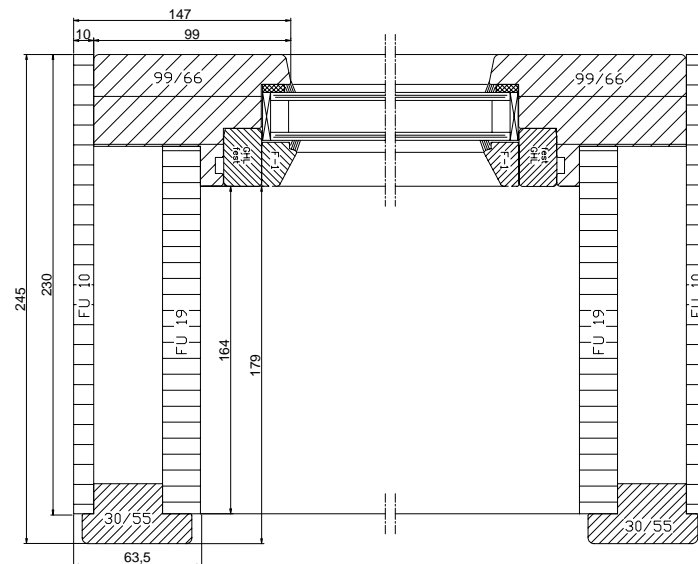

# Systeminformation

VSF 11011

Schnitt C - C

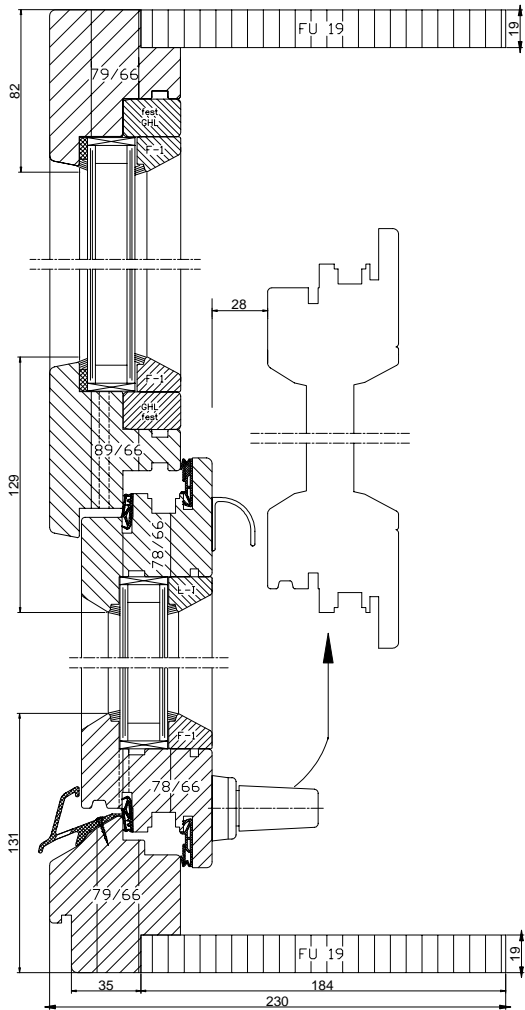

VSF 21021 /  
21041 / 21051 / 31061 / 31071  
Schnitt D - D

mit Regenschiene

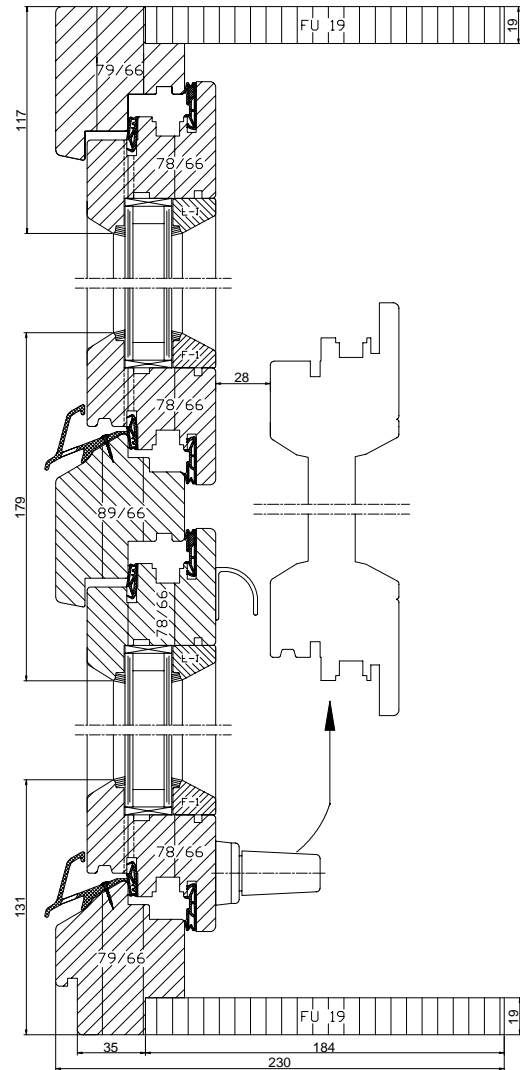

VSF 31061

Schnitt F - F

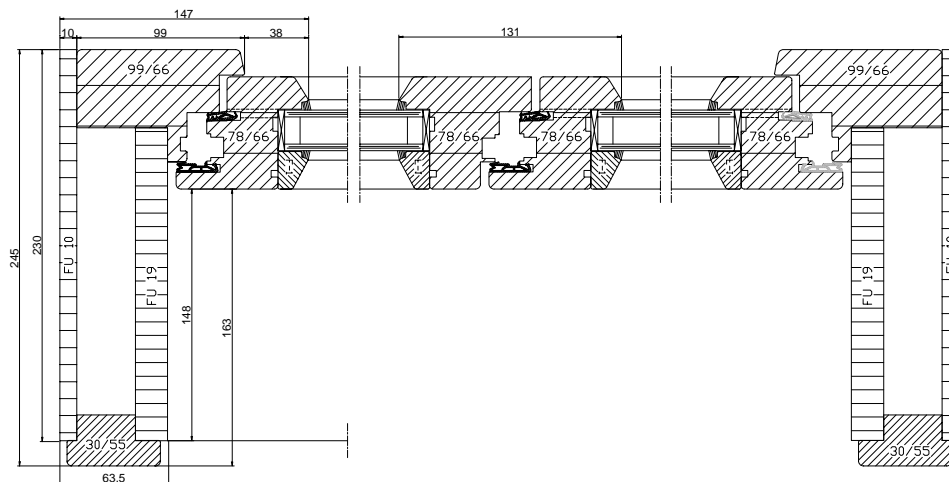

-  
Schnitt E - E

VSF 21031

*mit Regenschiene*

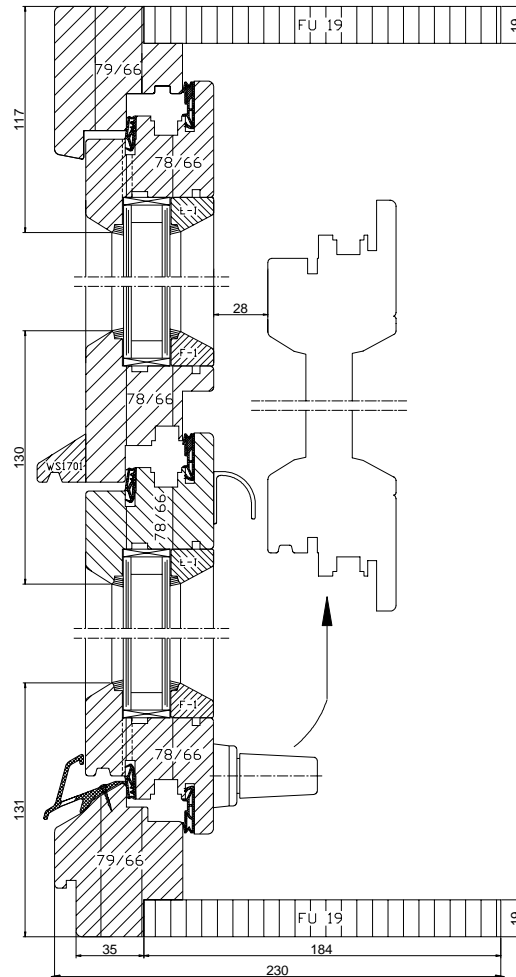

-  
Schnitt G - G

VSF 31071

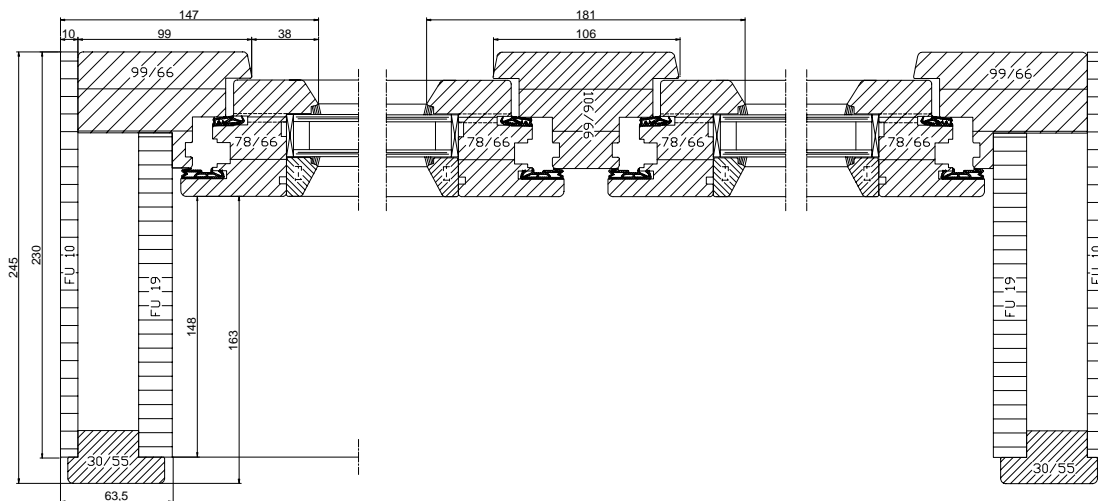

Hochschiebefenster Holz Typ "S" ohne unteres Rahmenquerstück (Verkaufsfenster)

www.adrik.de

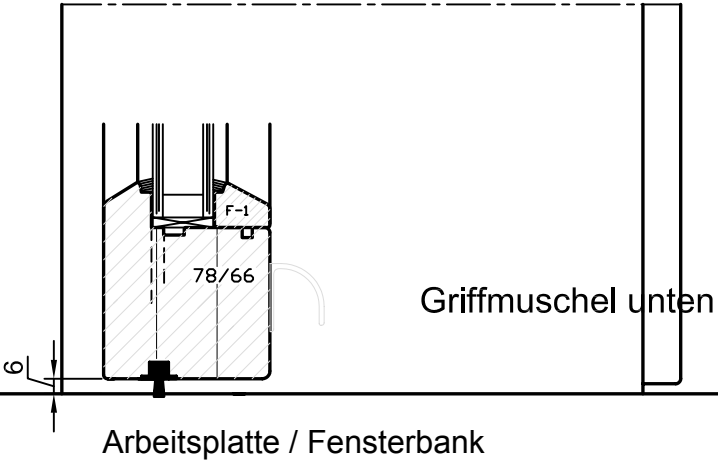
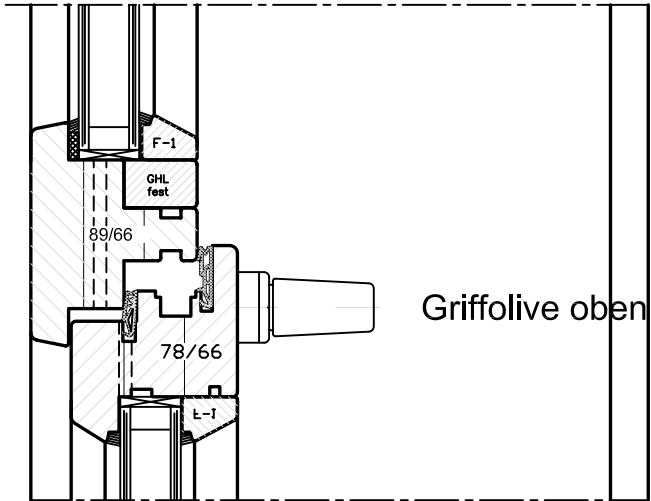
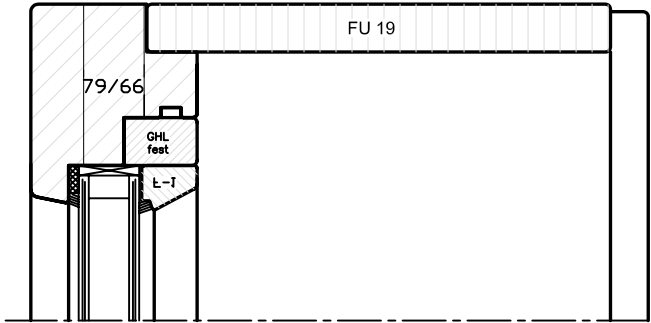

Bemerkung:  
Die Dichtigkeit in Bezug auf Regen o.ä. und Wind ist im unteren Bereich stark eingeschränkt !

# Detail Kopplung von 2 Hochschiebefenster Typ "S"

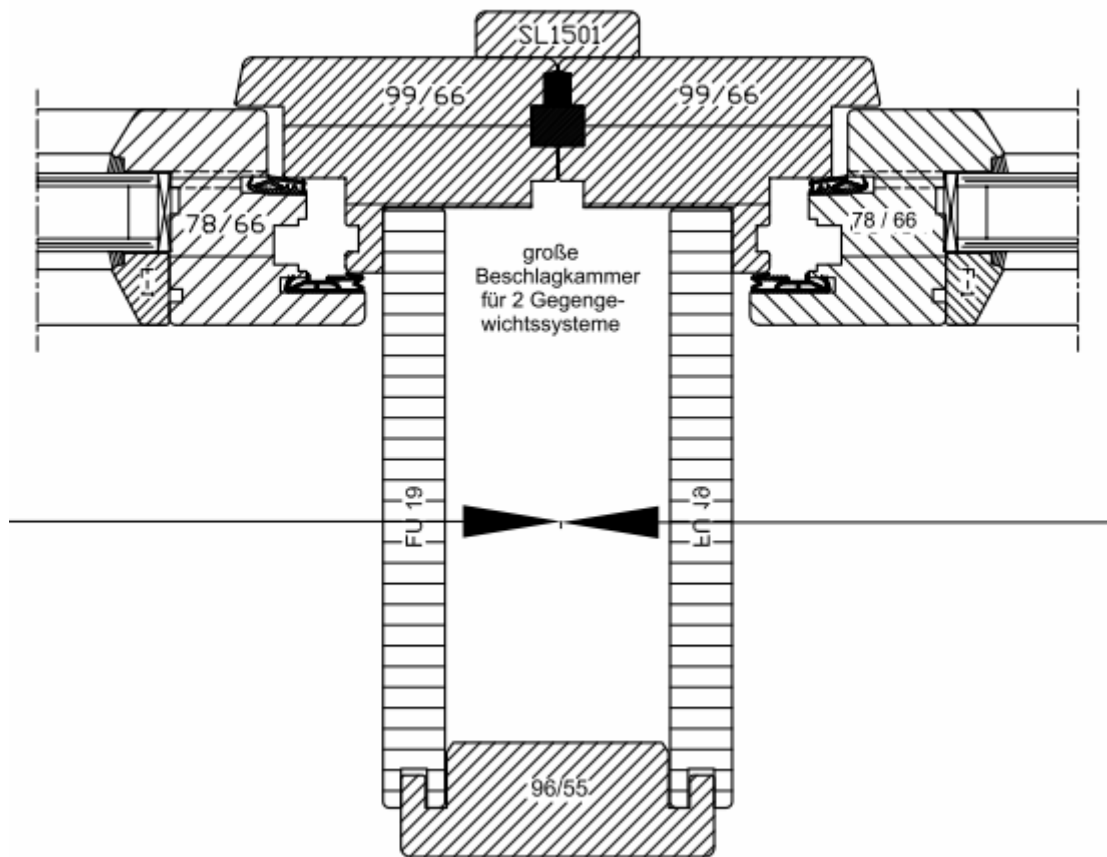

# Kopplung von 3 Hochschiebefenster Typ "S"

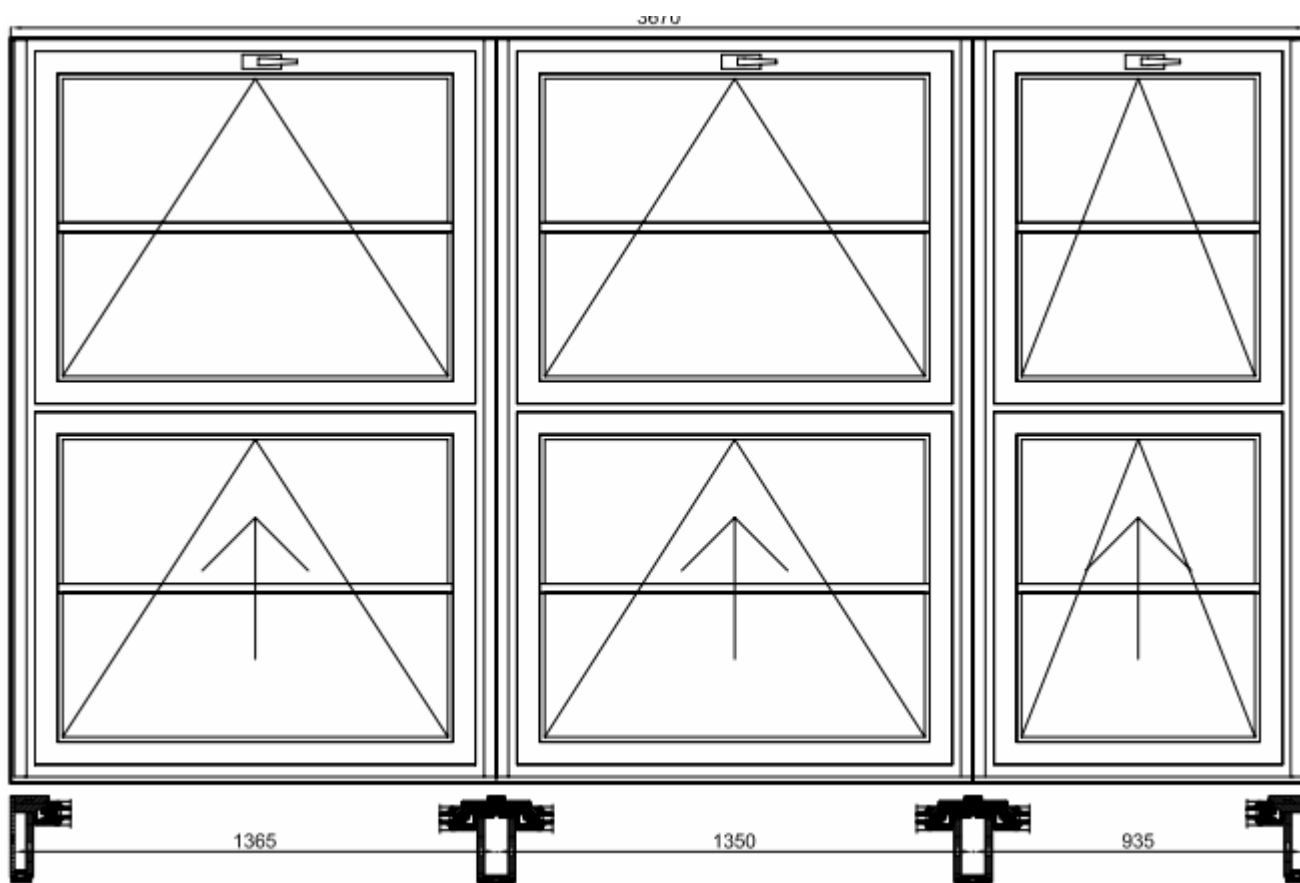

# Systeminformation Holz-Alu Hochschiebefenster

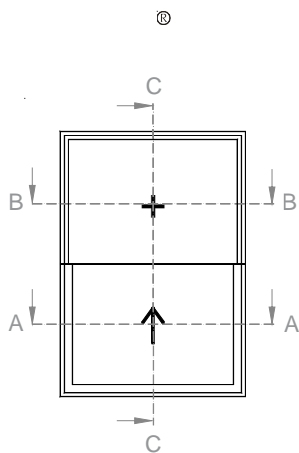

**VSF-HoMe 11011**

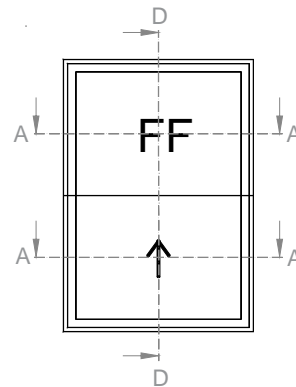

**VSF-HoMe 21021**  
*als Kämpfer  
waagrecht*

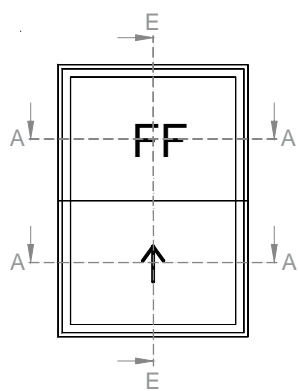

**VSF-HoMe 21031**  
*als Stulp  
waagrecht*

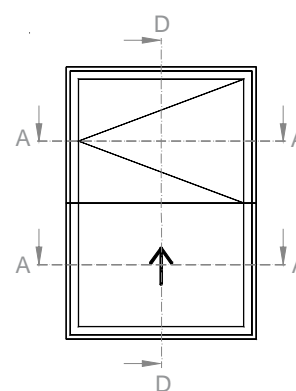

**VSF-HoMe 21041**

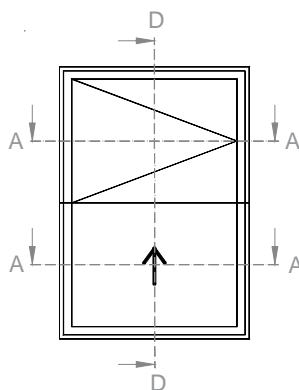

**VSF-HoMe 21051**

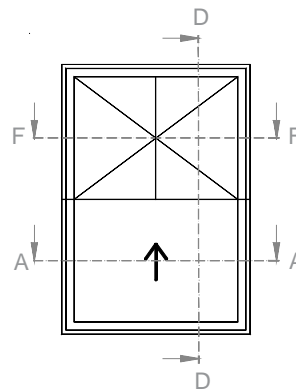

**VSF-HoMe 31061**  
*als Stulp*

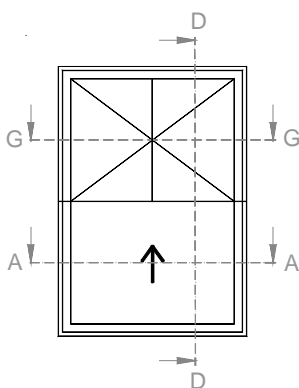

**VSF-HoMe 31071**  
*mit Pfosten*

- A ®  
21051 / 31061 / 31071  
Schnitt A - A

VSF-HoMe 11011 / 21021 / 21031 / 21041 /

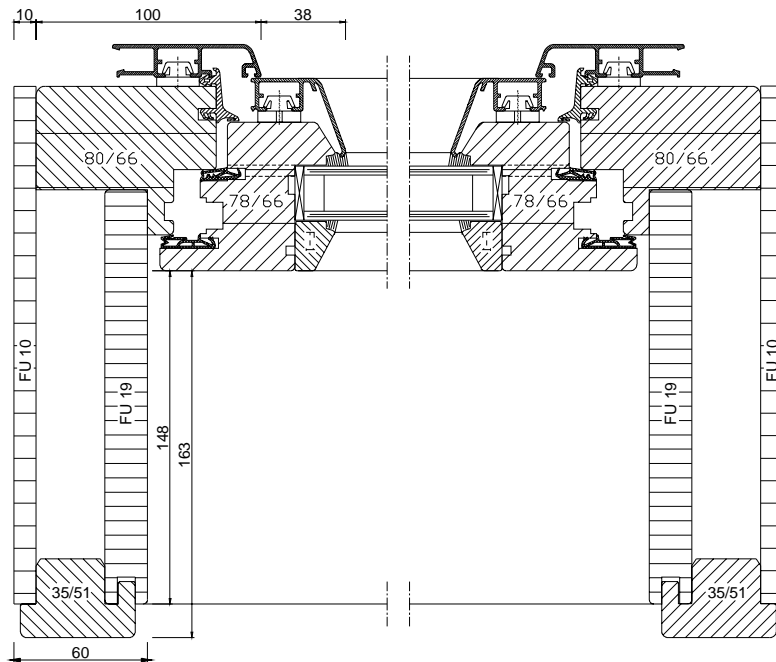

®  
Schnitt B - B

VSF-HoMe 11011

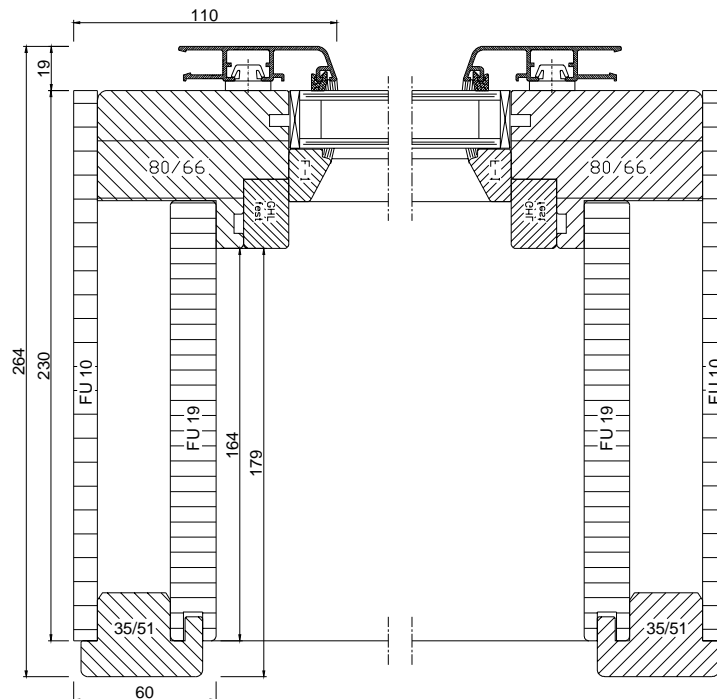



# Systeminformation

® (Holz-Metall) -  
Ausführung VSF-HoMe 11011  
Schnitt C - C

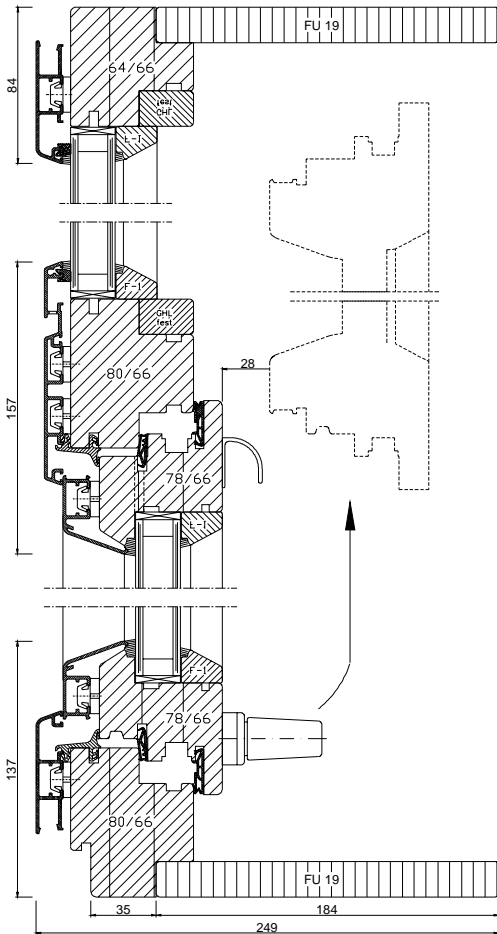

® (Holz-Metall) -  
Ausführung VSF-HoMe 21021 /  
21041 / 21051 / 31061 / 31071  
Schnitt D - D

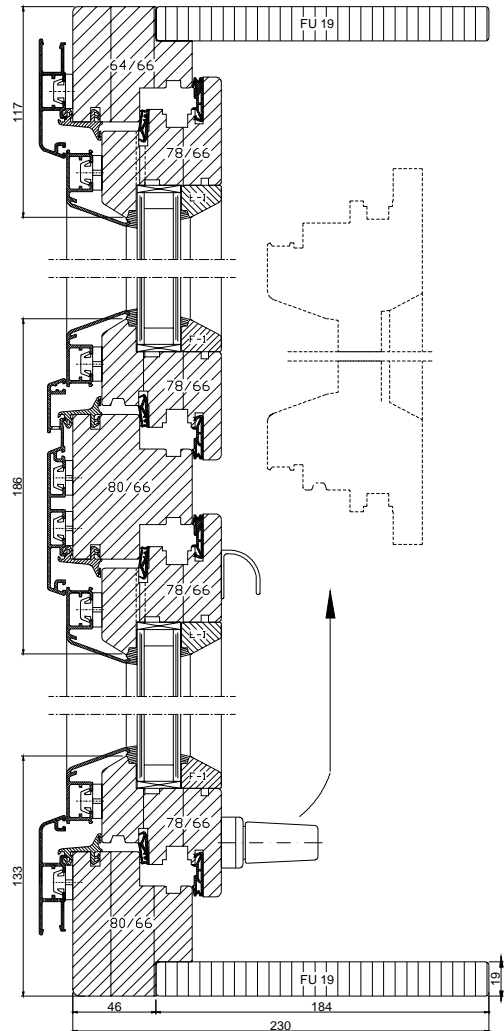

® (Holz-Metall) -  
Ausführung VSF-HoMe 31061  
Schnitt F - F

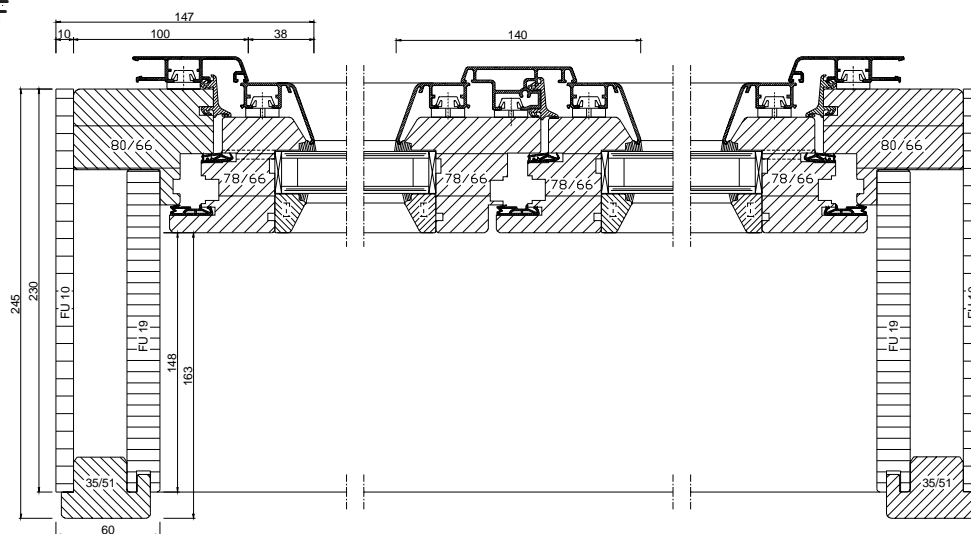

## ® (Holz-Metall) - Ausführung VSF-HoMe 21031

### Schnitt E - E

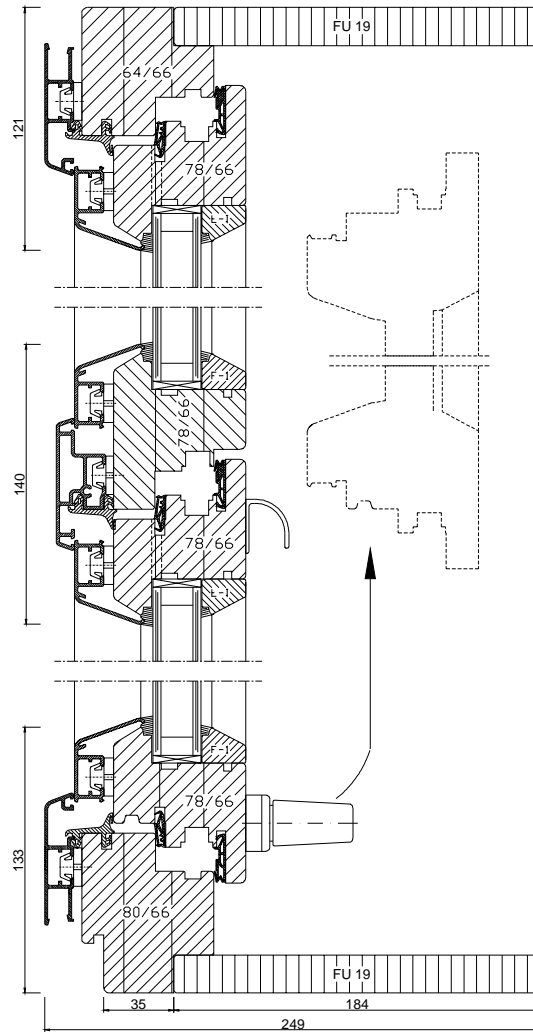

## ® (Holz-Metall) - Ausführung VSF-HoMe 31071

### Schnitt G - G

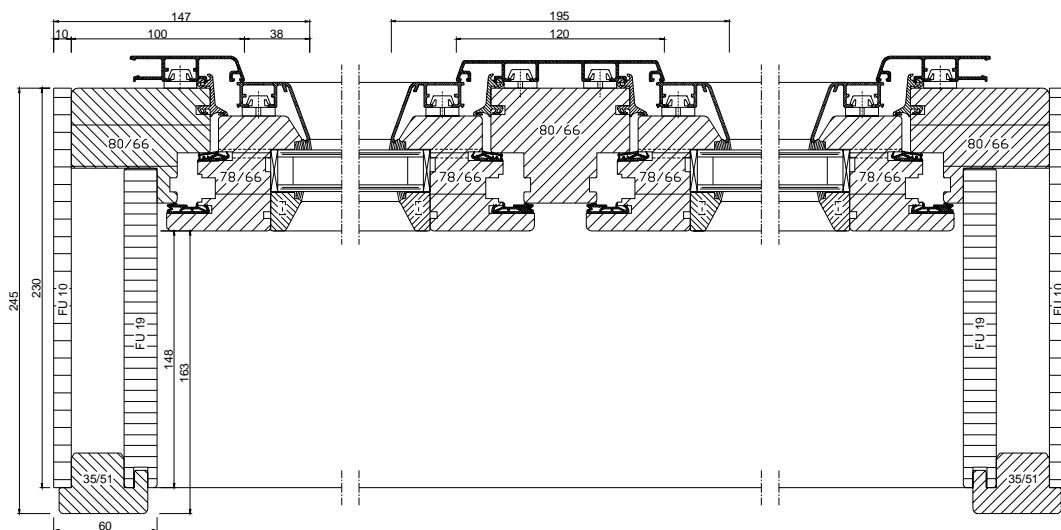

Info

1